



PWOC

Protestant Women of the Chapel

WORKSHOP: THE LEADERSHIP LENS:

Leading Through the Lens of the Gospel

by Heather Anne Ward

PARTICIPANT'S GUIDE

RELEVANCE: The "lens" we use to view the world around us is essential to our understanding of the truth, which impacts the characteristics and quality of our leadership. How leaders view the people they are leading, the issues they encounter, and their motives for leading are defined by which *lens* they use. For a gospel-centered leader, their lens is the gospel- the truth of the Word of God. This lens brings clarity and visibility to the leader's view, which in turn impacts their understanding of the world around them and their response to it. Without the gospel as the leader's lens, their view becomes distorted, and their quality of leadership is significantly diminished. Therefore, the truth found in God's Word is the foundation of a thriving leader.

1. THE LENS: THE GOSPEL

What kind of lens do you use to view the world around you?

- What is the gospel?
- Key Verse: **2 Corinthians 5:21** *God made him who had no sin to be sin for us, so that in him we might become the righteousness of God. (NIV)*
- The bottom line of the gospel is that it's all _____.

The gospel is therefore central to all theological truth, and is the overarching reality that makes sense of all reality. - Dave Harvey, When Sinners Say "I Do"



This work is licensed under the Creative Commons Attribution-NonCommercial-NoDerivs 3.0 Unported License. To view a copy of this license, visit <http://creativecommons.org/licenses/by-nc-nd/3.0/> or send a letter to Creative Commons, 444 Castro Street, Suite 900, Mountain View, California, 94041.

THE "GOSPEL WHEEL"

from Awana Clubs International, www.awana.org

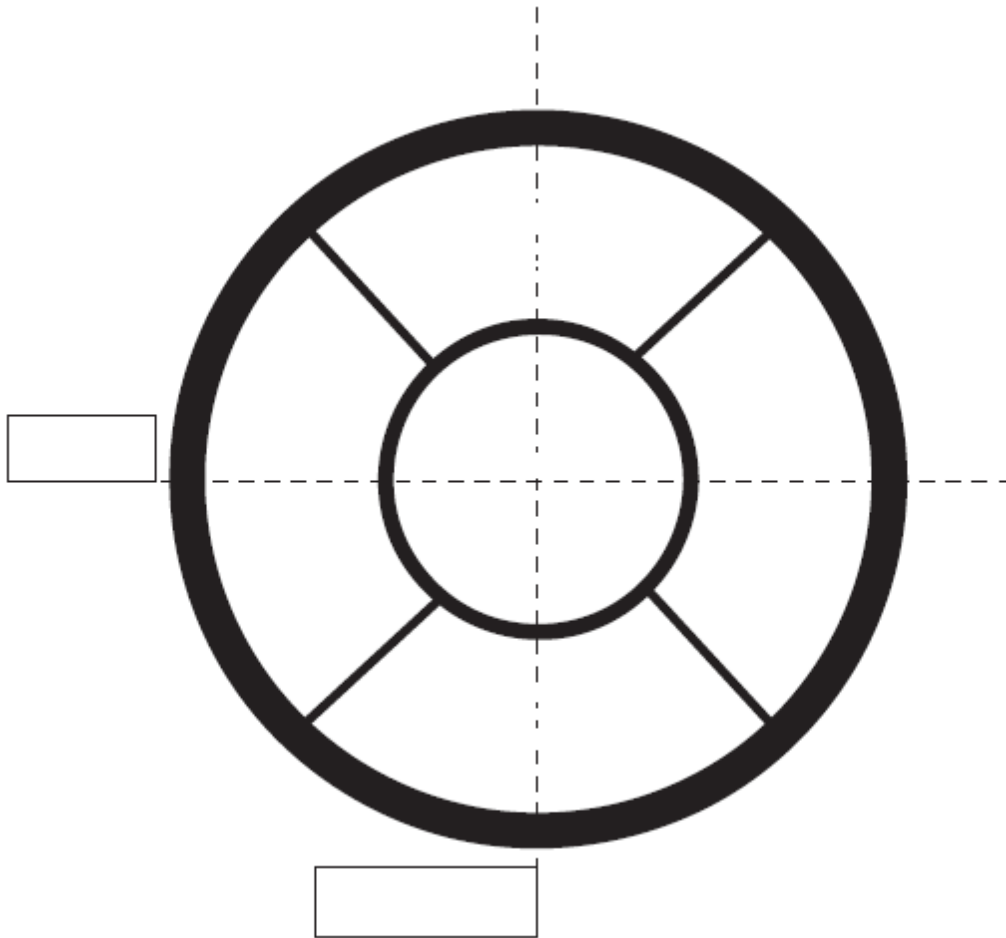

This work is licensed under the Creative Commons Attribution-NonCommercial-NoDerivs 3.0 Unported License. To view a copy of this license, visit <http://creativecommons.org/licenses/by-nc-nd/3.0/> or send a letter to Creative Commons, 444 Castro Street, Suite 900, Mountain View, California, 94041.

PRACTICE GOSPEL WHEEL

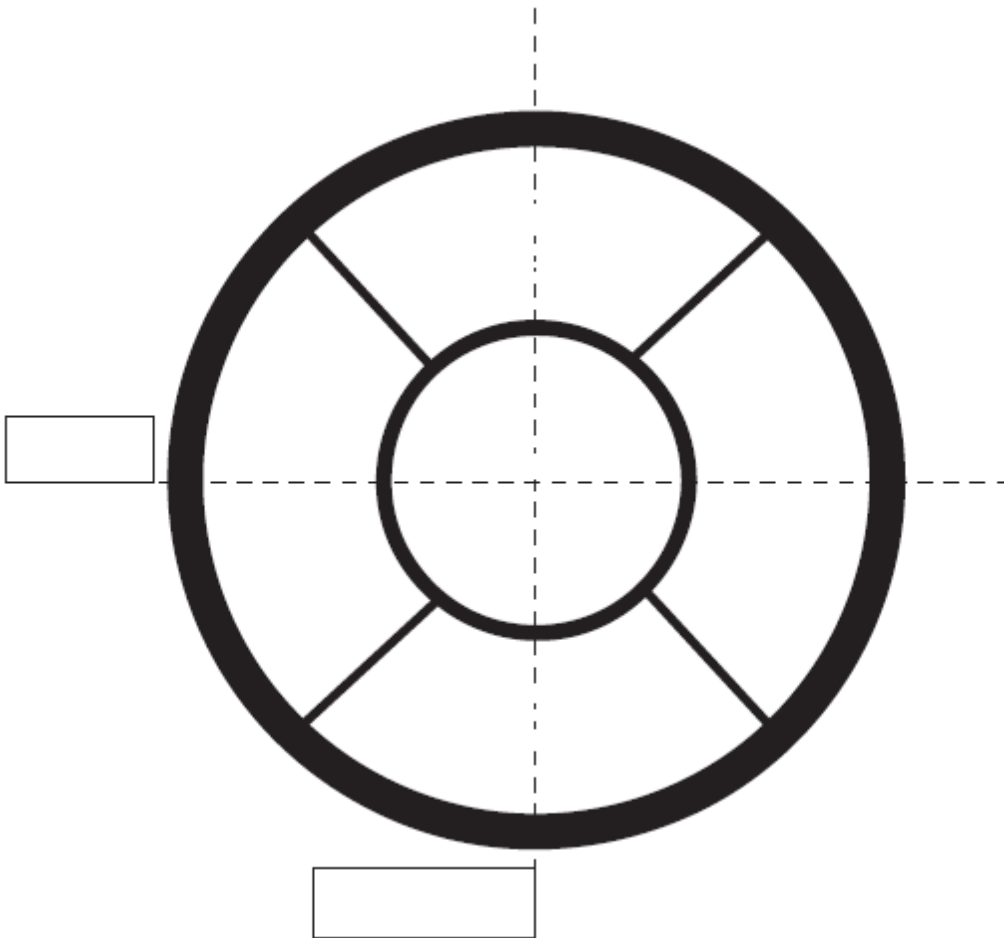

This work is licensed under the Creative Commons Attribution-NonCommercial-NoDerivs 3.0 Unported License. To view a copy of this license, visit <http://creativecommons.org/licenses/by-nc-nd/3.0/> or send a letter to Creative Commons, 444 Castro Street, Suite 900, Mountain View, California, 94041.

II. THE OBSERVER: CHARACTERISTICS OF A GOSPEL-CENTERED LEADER

- **Read the following excerpt and underline or highlight words or phrases that stand out to you. If you desire, make notes in the margins. Be prepared to share the characteristics that stood out to you when we come together again.**

This excerpt is taken from Chapter 9 of Creature of the Word: The Jesus-Centered Church by Matt Chandler, Josh Patterson, and Eric Geiger. Copyright 2012.

Godly leadership is stewardship. It is the recognition that personal agendas, entitlements, vainglory and selfish ambition must be put to death. A leader who is transformed by the gospel seeks not to make a name for himself but to lift high the name of Jesus. His obsession is not with building his own empire, but living for the kingdom of God.

What IS Gospel-Centered Leadership?

Most Christian approaches to leadership simply find good and bad examples of leaders in the Bible and say, "Be like this," or "Don't be like that." Although the Bible certainly provides great examples of leadership, these approaches often assume the Bible is a book primarily about you and what you are to do, rather than primarily about God and what He has done in Christ.

Gospel-centered leadership does not begin with the command to imitate, but with the good news that God is gracious and has sent His Son to take our sins and give us life.

So, yes, gospel-centered leadership may end up looking like Nehemiah or Moses, but that's because it's grounded in being united to the One toward whom they point: Jesus. When you're united to the One who died on the cross and rose from the grave, then your life (and your leadership) is shaped by dying to self and allowing Christ to live in you.

In light of all of this, how can we best understand and define leadership, specifically gospel-centered leadership?

Jesus-centered leadership is God-focused, Christ-exalting and Spirit-led influence toward a kingdom agenda. Gospel-centered leadership is inextricably linked to the work of the triune God in redemption. The gospel is Trinitarian. The Father sends, the Son accomplishes, and the Spirit applies. Thus, gospel-centered leadership is marked by its redemptive influence and kingdom initiatives.



This work is licensed under the Creative Commons Attribution-NonCommercial-NoDerivs 3.0 Unported License. To view a copy of this license, visit <http://creativecommons.org/licenses/by-nc-nd/3.0/> or send a letter to Creative Commons, 444 Castro Street, Suite 900, Mountain View, California, 94041.

This definition is in accord with the theological grid distilled from the Scriptures. Gospel-centered leadership focuses on the glory of God and is grounded in God's reign and rule.

Gospel-centered leadership aims to exalt Christ Jesus in all things and is sourced in His Person and work. He is the Chief Shepherd, the Senior Pastor and Head of the body.

Gospel-centered leadership recognizes that we cannot afford to be self-directed in our influence; rather we must be Spirit-led. All of our influence and inertia is toward advancing the kingdom of God by pushing back the darkness.

- **Characteristics of a gospel-centered leader:**

III. THE VIEW: HOW A GOSPEL-CENTERED LEADER FUNCTIONS

- Philippians 3:12-14 *Not that I have already obtained all this, or have already been made perfect, but I press on to take hold of that for which Christ Jesus took hold of me...But one thing I do: Forgetting what is behind and straining toward what is ahead, I press on toward the goal to win the prize for which God has called me heavenward in Christ Jesus. (NIV)*
- Philippians 4:6-7 *Do not be anxious about anything, but in everything, by prayer and petition, with thanksgiving, present your requests to God. And the peace of God, which transcends all understanding, will guard your hearts and your minds in Christ Jesus. (NIV)*
- 2 Corinthians 10:5 *We demolish arguments and every pretension that sets itself up against the knowledge of God, and we take captive every thought to make it obedient to Christ. (NIV)*



This work is licensed under the Creative Commons Attribution-NonCommercial-NoDerivs 3.0 Unported License. To view a copy of this license, visit <http://creativecommons.org/licenses/by-nc-nd/3.0/> or send a letter to Creative Commons, 444 Castro Street, Suite 900, Mountain View, California, 94041.

- Colossians 2:8 *See to it that no one takes you captive through hollow and deceptive philosophy, which depend on human traditions and the basic principles of this world rather than on Christ. (NIV)*

ACTIVITY:

The trainer will divide the participants into three groups. Each group will be given a different scenario to read and then develop a response based on a leader who uses the gospel as their lens. Your group will have the opportunity to share your thoughts.

Scenario 1:

You are the Retreat Coordinator. The fall retreat was a huge success, and your retreat committee really helped to pull it all together. The Installation Chaplain heard about the successful retreat, and he made a point to congratulate you in person.

The Retreat Coordinator's Gospel-Centered Response:

Scenario 2:

You are the local PWOC President. Every week, one particular lady makes a point of coming to you during fellowship time with a list of complaints: she doesn't like the Bible studies that are offered, the praise and worships songs aren't her taste, and the snacks they give her daughter in watch care aren't the ones she prefers, etc.

The President's Gospel-Centered Response:



This work is licensed under the Creative Commons Attribution-NonCommercial-NoDerivs 3.0 Unported License. To view a copy of this license, visit <http://creativecommons.org/licenses/by-nc-nd/3.0/> or send a letter to Creative Commons, 444 Castro Street, Suite 900, Mountain View, California, 94041.

Scenario 3:

You are the Program VP, and you love planning and preparing the programs for PWOC. This month you have the great idea to use helium balloons to decorate the ceiling. You and your team fill the balloons with helium the day before the program. The decorations look great! But, when you come in the next morning for the program, the balloons have all fallen down and are deflated.

The Program VP's Gospel-Centered Response:

"Accurately understanding and continually applying the Gospel IS the Christian life." -- Dave Harvey, When Sinners Say "I Do,"

APPLY IT TO LIFE:

1) **Pray** and ask God to show you **one** area that needs refining in order to make you more effective as a leader.

- Do you need to make the gospel your lens?
- Is there a lens in which you've been operating that needs to be removed?
- Do you need to commit to apply a specific habit in order to make the gospel central to your life, such as consuming God's Word daily and/or developing a perpetual prayer life?
- Is there something you need to follow up on or ask forgiveness, because you didn't lead with a gospel lens?

2) Whatever it is, **write it down as a statement** of how you will practically commit to making the gospel central to your life and as a leader. **To make the Gospel central to my life, I will commit to:**



3) Consider using a blank 4x6 card to **write down one of the verses** we talked about. Carry this card with you or put it where you will see it throughout your day as you learn to walk with the gospel-centered vision in your leadership.

Resources:

- Cross, John R., *The Stranger on the Road to Emmaus*, 2011 by Good Seed International
- Dodson, Jonathan K., *Gospel Centered Discipleship*, 2012 by Crossway
- Harvey, Dave, *When Sinners say "I Do,"* 2007 by Shepherd Press
- Mahaney, C. J., *The Cross Centered Life*, 2002 by Sovereign Grace Ministries



This work is licensed under the Creative Commons Attribution-NonCommercial-NoDerivs 3.0 Unported License. To view a copy of this license, visit <http://creativecommons.org/licenses/by-nc-nd/3.0/> or send a letter to Creative Commons, 444 Castro Street, Suite 900, Mountain View, California, 94041.